

S.50-928

Ideal choice for very heavy transportation.
Assembling belt for cars and truck loading systems.
FDA approved.

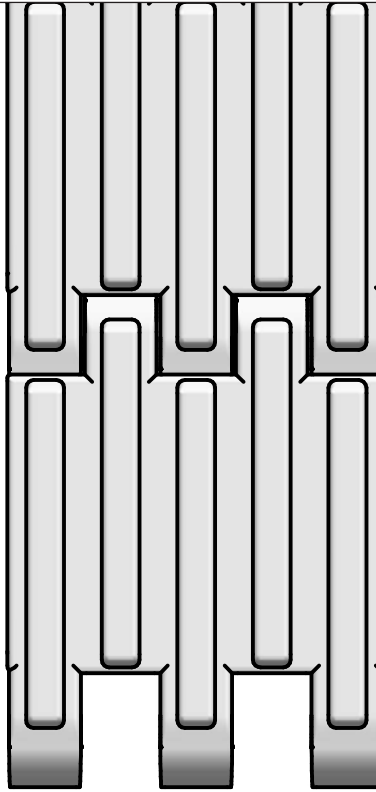

SCANBELT
...keeping industry moving...



PROTECTED BY THE EU DESIGN REGISTRATION

SUGGESTED INDUSTRIES



STANDARD FEATURES

Belt surface	Raised rib 5 mm
Open area	Closed
Strength	Ideal choice for very heavy-duty transportation
Cleanability	Good
Standard width	Increments of 20 mm, e.g. 100, 120 mm etc.

BELT DATA

Belt materials	Temperature range		Max. belt pull kg/m of width	Belt weight kg/m ²	Belt weight kg/m ² w. steel rods	Standard Colours
	Min.	Max.				
PE	- 73	66	4800	16	22	Black
PP	+ 5	100	6000	16	22	Black
POM	- 43	95	10250	24	30	Black

ACCESSORIES

Type	mm
Flights	25
Scoop Flights	-
Bent Flights	-
Supported Flights	-
Comb Flights	25, 50, 60
Flights fitted with a Round Top	-
Moulded Side Guards	40
Friction Top	-
Hold-downs	-

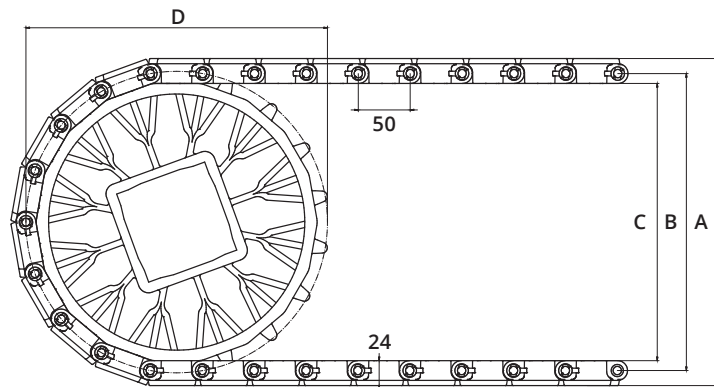

SPROCKET DATA

A = Outside, B = Pitch, C = Inside, D = Pitch Circle Diameter

No. Teeth	A	B	C	D	Hub Width	Round Bore		Square Bore	
	mm	mm	mm	mm		mm	Inch	mm	Inch
12	217	188	169	195	40	40 / 60		60 / 80 / 90	
16	283	254	235	259	40	40 / 60		60 / 80 / 90	
18	317	288	269	291	40	40 / 60		60 / 80 / 90	